

# Fork Grapple Specification Table

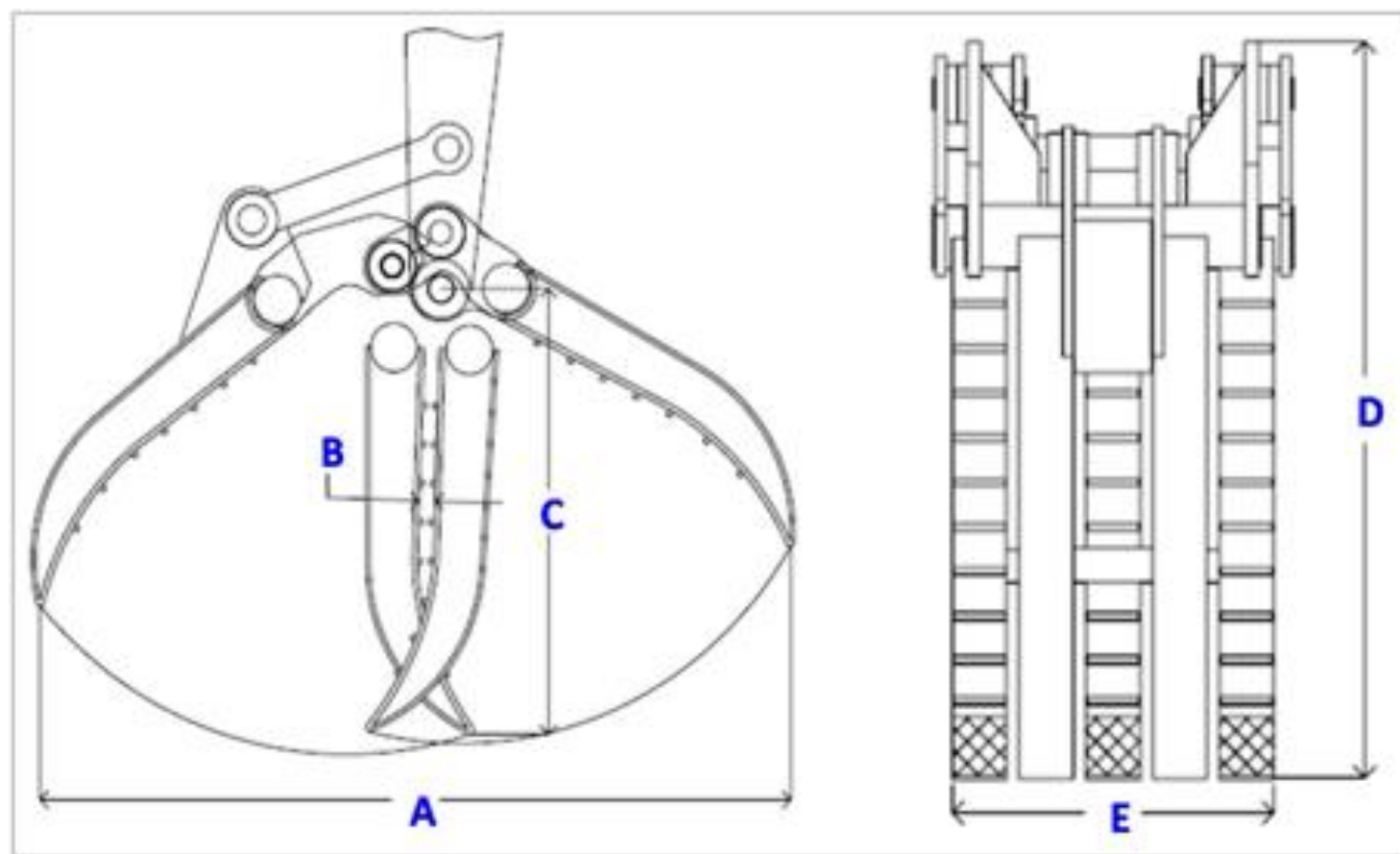

Model	Excavator Class	Approximate Weight		A Max Jaw Opening		B Min Gap Between Jaws		C Length of Tines		D Height		E Width	
		kg	lb	mm	Inch	mm	Inch	mm	Inch	mm	Inch	mm	Inch
FC46	3 – 5 (6,600 – 11,000)	285	630	1,241	48	25	1.0	710	28	885	35	495	19
FC56	6 – 8 (13,200 – 17,600)	360	792	1,700	67	30	1.2	945	37	1,170	46	520	21
FC76	9 – 12 (19,800 – 26,400)	500	1,100	1,950	76	40	1.6	1,047	41	1,300	51	745	29
FC88	18 – 21 (39,600 – 46,200)	785	1,727	2,302	90	50	2.0	1,310	52	1,620	64	810	32
FC98	24 – 29 (52,800 – 63,800)	1,178	2,592	2,900	113	60	2.5	1,710	67	2,120	83	850	34

\*Dimensions are for reference only, it may vary from excavator brands and models

\*\*For the benefit of continuous product improvement, specifications are subjected to change without prior notice.